



Helping Power
Reach People
Since 1959

“ WORDS FROM OUR LEADERS

In my long career of more than 50 years in business, I have learnt one of the most valuable lessons to achieve positive output is to establish trust and keep innovating. I believe in teamwork and I am confident that Team IAC will touch new heights in the years to come

**- Brij Mohan Garodia
Chairman**



As the Managing Director, I am thrilled to introduce you to our esteemed organization. Our team, with its unwavering dedication and expertise, is the cornerstone of our success. At IAC, we are driven by a passion for excellence and a commitment to providing superior electrical solutions. Our dedication to quality and innovation stands at the core of our business, guiding us in delivering products and services that not only meet but exceed the expectations of our diverse clientele.

Thank you for your trust in IAC

**- Adarsh Garodia
Managing Director**



OUR VISION

To deliver quality products to meet the requirements of our valued customers, the first time, every time.



OUR MISSION

Continual improvement in products and processes by different innovative means to deliver quality products to customers.



QUALITY POLICY

Ensure total customer satisfaction all the time through the best quality products and services. Ensure to adhere to applicable legal & regulatory requirements, continual improvement in all fields of activities and the best utilisation of human resources.

TOP 1% BUY FROM US

6500

PROJECTS COMPLETED

1.1 KV - 1200 KV

COMPLETE SOLUTION

45

COUNTRIES SUPPLIED

ISO/IEC : 17025

NABL ACCREDITED LABORATORY

CERTIFIED QUALITY

The quality, performance and reliability of our systems, products & services are assured by the following certifications:



FOR ISO CERTIFICATE,
PLEASE SCAN THE QR CODE.

6 DECADES OF ENGINEERING EXCELLENCE



Started **manufacturing of Sub-Station and Hardware Fittings**

1959-1970

1980-1983

Executed first **export project to Bhutan**

Supply of first **400kV Hardware Fittings**

Technology Transfer to **IAC Electricals Sdn. Bhd. Malaysia.**

Certified **ISO 9000:2000 QMS**

1998-2001

2010-2012

Upgraded **manufacturing facility** of factory **15,000 sq. mtr.**

Manufacturing of **Spacer Damper** and supply of **765 kV Hardware Fittings**

Started **Hot Dip Galvanising Facility**

Supply of **220kV sub-zero Hardware Fittings to Powergrid (-45°C) and OPGW Fittings**

2014-2016

2017-2019

NABL accreditation of in-house testing lab as per IEC: 17025/2015

Approval & Supply of **HTLS Fittings (ACCFCC & ACFR) Covered Conductor Fittings**

Supply of **800kV HVDC Fittings to Powergrid**

Bagged largest order of **19 million USD** from Ethiopian Electricity utility

2020-2023

OUR REACH OVER THE WORLD

45+ COUNTRIES REACHED



- Afghanistan
- Algeria
- Bangladesh
- Benin
- Bhutan
- Burkinafaso
- Burundi
- Cambodia
- Cameroon
- Congo
- Egypt
- Eswatini
- Ethiopia
- Gambia
- Guinea
- Iraq
- Italy
- Ivory Coast
- Jordan
- Kenya
- Laos
- Liberia
- Malawi
- Malaysia
- Mali
- Mozambique
- Nepal
- Nicaragua
- Niger
- Nigeria
- Oman
- Peru
- Philippines
- Rwanda
- Senegal
- Sierra Leone
- Spain
- Srilanka
- Tanzania
- Togo
- UAE
- Uganda
- Uruguay
- Zambia

- LV/MV Pole line Fittings & Accessories
- Galvanized Steel Structure
- Medium Voltage Covered Conductor Accessories
- LT AB Cable Fittings & Accessories

- Insulator Hardware upto 1200KV HVAC & 800KV HVDC
- Conductor Accessories
- OPGW Fitting & Earthing Accessories
- HTLS Conductor Fittings



- Sign / Warning Plates
- Earthing Accessories
- Bird Guard / Bird Diverter
- Aircraft Warning Sphere

- Insulator Hardware
- Clamp & Connectors
- Busbars
- Earthing

SOME MAJOR CLIENTS



Benin



Bhutan



Srilanka



Oman



Cambodia



Rwanda



Laos



Mozambique



Eswatini



Ethiopia



Malawi



Iraq



Jordan



Kenya Power
Kenya



Liberia



Philippines



Nepal



Niger



Bangladesh

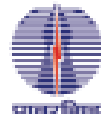

Powergrid



Burundi



Burkina Faso



Cameroon



Tanzania



Nigeria



CLSG



Uganda



Uruguay



Zambia

MANUFACTURING FACILITIES

Our factory is equipped with the most modern machines around Kolkata, India. We have an experienced technical team and a dedicated workforce to ensure quality products as well as the timely execution of orders.

MAJOR MANUFACTURING MACHINES/EQUIPMENT AVAILABLE WITH US

1. VMC Machine
2. CNC Lathe Machine
3. Injection Moulding Machine
4. Pressure Die Casting Machine
5. Laser Cutting & Marking Machine
6. Automatic Pipe Bending Machine
7. Hot Dip Galvanise Facility
8. Helical Forming, Cutting & Bending Machine
9. Induction Heating & Forging
10. MIG & TIG Welding
11. 3D Printing Machine
12. Hydraulic & Power Press Machine
13. Angle/Channel Cutting Machine

FOR MANUFACTURING IMAGES,
PLEASE SCAN THE QR CODE.



TESTING FACILITIES

Facilities of IAC Research and testing laboratory is ISO/IEC 17025 accredited by **NABL** India for testing of products in the disciplines of Electrical, Mechanical and Chemical.

THE SCOPE OF VARIOUS TESTING DISCIPLINES ARE AS BELOW:

1. Heating cycle/temperature rise
2. Magnetic power loss
3. Type tests on ACSR/AAAC/AAC conductor
4. Type tests on HTLS conductor (tests at elevated temperature, creep test, Axial impact test and Sheeve test)
5. Vibration/fatigue test on insulator strings/conductors
6. Mechanical (tensile, compression, torsion, Bending tests) On insulators
7. Tests on vibration damper , Spacer damper and RIGID spacer
8. Chemical composition of ferrous and non ferrous

FOR TESTING IMAGES,
PLEASE SCAN THE QR CODE.



BROAD PRODUCT CATEGORIES

**SUSPENSION INSULATOR
HARDWARE FITTINGS**



**TENSION INSULATOR
HARDWARE FITTINGS**

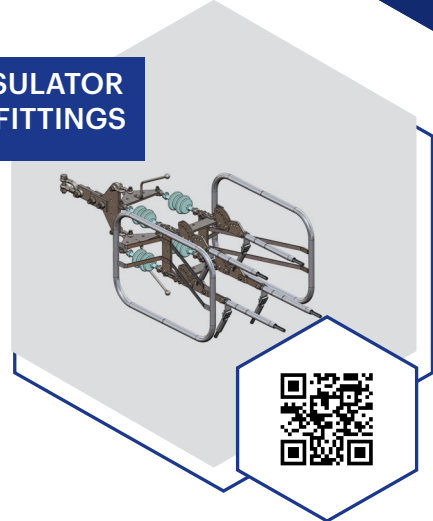

**SPACER DAMPER
& RIGID SPACER**

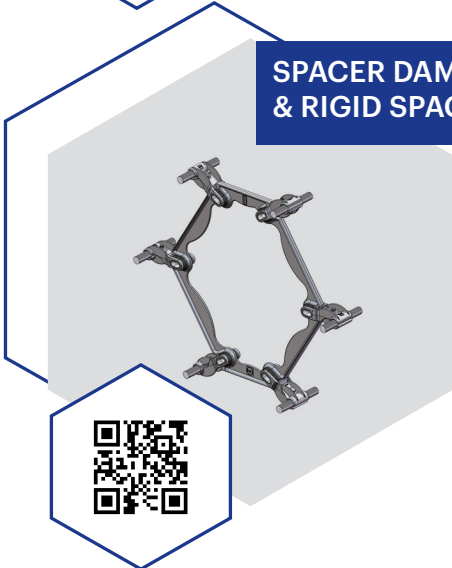

**STEEL FABRICATIONS
& CROSSARMS**



**AB CABLE FITTINGS
& ACCESSORIES**



**COVERED CONDUCTOR
FITTINGS**

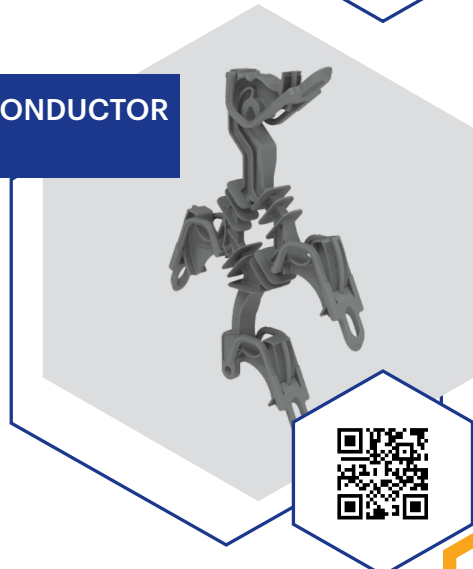

BROAD PRODUCT CATEGORIES



**SUB-STATION
HARDWARE**

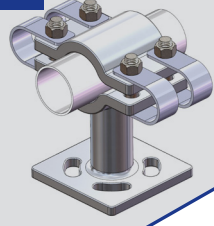

**SUB-STATION CLAMPS
& CONNECTORS**





**CONDUCTOR, EARTHWIRE
& OPGW ACCESSORIES**

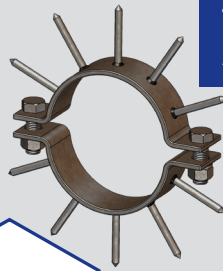

**EARTHING
ACCESSORIES**



**TOWER /POLE
ACCESSORIES**



**ANCHOR & STAY
SETS**



OTHER SOCIAL INITIATIVES BY IAC

IAC Electricals joined hands to elevate the well-being of 6 adjoining villages with several camps and relief measures. 80% of the inhabitants in these areas are below the poverty line. From 2012 onwards, we have strived to uplift these villages.



REGULAR EYE CAMPS

1. 1500 free eye examinations conducted
2. 84 free eye microsurgeries Performed
3. 600 spectacles provided at a minimal cost
4. Free medicines distributed



FLOOD RELIEF

1. Distributed 90 water tents
2. Distributed half week's worth of food to 210 families & provided free food to 500 people
3. Rebuilt the houses of 35 needy families



DRINKING WATER PROJECT

1. Provided 100% certified drinking water to villagers
2. 338 families benefitted
3. Water pipeline covering approx 10kms in 5 villages



**FOR MORE CSR DETAILS,
PLEASE SCAN THE QR CODE.**



**VIEW OUR COMPANY
PROFILE HERE**



IAC Electricals Pvt Ltd

Email: info@iacelectricals.com

Phone: +91-33-2485-8814 / 15

Website: www.iacelectricals.com

CORPORATE OFFICE:

506, Central Plaza,
2/6 Sarat Bose Road,
Kolkata 700020, India.

WORKS:

Sankrail Industrial Park, Plot-53,
NH-6, Jaladhulagori,
Howrah - 711203, India.